

AIRPAX DIMENSIONS

Airpax Dimensions, Inc.
4467 White Bear Parkway
St. Paul, MN 55110-7626

(651) 653-7000
Fax (651) 653-7600

121475B

OWNERS MANUAL

JANUARY 2007

ISO 9001:2000 Certified Company



Airpax Dimensions, Inc. DC to AC Power Inverters

OWNERS MANUAL for Model:

12/600

Including Options: B, J, L & T

OWNERS MANUAL FOR AIRPAX DIMENSIONS INVERTERS

Model ADI-12/600
Including Options J, L, T

Table of Contents

	<u>Page</u>
1. General	2
2. Description	2
3. Installation	3
4. Start Up/Operation.	4
5. Troubleshooting.	4
6. Installation Figure 1	5
7. Limited Warranty.	6

1. GENERAL

1.01 Dimensions inverters have been designed and manufactured for many user applications and long life. They utilize patented construction methods and high technology electronic parts and circuitry.

1.02 CAUTION: Inverters produce hazardous voltage. To avoid risk of harm or fire the unit must be properly installed. There are no user servicable parts inside, do not remove the cover.

CAUTION: The inverter should not be mounted in a location that may be exposed to rain or spray.

CAUTION: The inverter should not be installed in a zero clearance enclosure.

CAUTION: Damage to the inverter will occur if correct polarity is not observed when installing the DC input cables.

CAUTION: Damage to the inverter will occur if an external AC power source is applied to the inverter's AC output or its hardwire output.

CAUTION: The inverter contains a circuit breaker and capacitor that may produce a spark. Do not mount in a confined battery or gas compartment.

CAUTION: Working in the vicinity of lead - acid

batteries is dangerous. Batteries generate explosive gases during operation. There is a risk of acid exposure. There is also a risk of high current discharge from shorting the battery that can cause fire and explosion.

CAUTION: Be sure both the inverter and, if used, the external AC input circuit breaker or fuse are turned "OFF" during installation.

2. DESCRIPTION

2.01 The inverter converts 12 VDC to 120 VAC, 60 HZ, having a quasi-sine wave form.

2.02 The inverter has a controlled frequency at 60 HZ \pm 0.6Hz.

2.03 The inverter has internal protection against output short circuit, output overload and high temperature conditions. Also, there is a thermally controlled cooling fan.

2.04 The inverter is designed to operate any 120 VAC, 60 HZ, single phase equipment within its power ratings, unless specifically designed for a pure sine waveform. Models with option "J" output filter are designed to operate specific loads such as television monitors.

Inverter Rating				
Inverter	Input		Output	
Model	(VDC)	(ADC)	(VAC, RMS)	(Watts)
12/600	12.6	Up to 60	120	600

3. INSTALLATION

3.01 The following instructions should be thoroughly read and understood before installation.

3.02 CAUTION: Inverters produce hazardous voltages. To avoid risk of harm or fire the unit must be properly installed.

CAUTION: Damage to the inverter will occur if correct polarity is not observed when installing the DC input cables.

CAUTION: Damage to the inverter will occur if an external AC power source is applied to the inverter's AC outlet or its hardwire output.

CAUTION: Be sure both the inverter and the external AC input circuit breaker or fuse are turned "OFF" during installation.

NOTE: All wiring must follow the National Electric Code, Provincial or other codes in effect at the time of installation, regardless of suggestions in this manual. All wires should be copper conductors.

3.03 Mounting

3.03.1 Locate a suitable, secure flat mounting surface as close to the battery as possible without being in the same compartment. The maximum recommended distance between the mounting location and the battery is 20 feet.

3.03.2 The location should have adequate ventilation and clearance to maintain room temperature while the unit is operating. At least 1/2 inch of clearance is required on all sides.

3.03.3 Secure the unit with #8 or larger screws or bolts in the mounting slots on the flanges of the chassis.

3.04 Chassis Bonding Lug - FIG. 1

3.04.1 Connect a #8 gauge or greater copper wire between the bonding lug on the inverter and the earth grounding system or the vehicle chassis.

3.05 Battery Wiring - FIG. 1

3.05.1 CAUTION: Make sure that hydrogen gas does not accumulate near the battery by keeping the area well ventilated. A spark may result when connecting the battery wiring due to an initial charging of the internal input capacitor.

3.05.2 The recommended stranded copper

wire between the battery and the inverter and the necessary line fuse are indicated:

Battery to Inverter Distance (feet)

	1-10	11 to 15	16-20
Cable	6 awg	4 awg	4 awg
Fuse	150A	200A	200A

3.05.3 U.L. codes require the use of an auxiliary fuse to be installed within 18 inches from the battery.

3.05.4 NOTE: Using smaller input cable or longer length will greatly degrade the inverter peak performance.

NOTE FOR VEHICLE INSTALLATION: Do not use the vehicle chassis as the negative return in place of a return cable. Use the same size cable as the positive connection and run directly to the battery/alternator.

3.05.5 Install the wires on the battery, inverter and then fuse holder. Make sure that tight, clean connections are made. Use care not to touch the positive and negative wires together. This will result in a violent spark and could result in exploding batteries and fire.

3.05.6 CAUTION: Connecting the inverter incorrectly to the battery with the polarity reversed will cause damage that is not covered under warranty!

3.05.7 Connect the White wire to the negative (-) post on the battery. Connect the Red wire to the positive (+) post on the battery. A mounting spark may result when connecting the battery wire.

3.06 Remote ON/OFF Switch - Fig. 1

3.06.1 A remote On/Off input is not provided with the "L" option.

3.06.02 If not used, no connection is necessary to the violet wire.

NOTE: Connecting this wire to ground will cause damage not covered under warranty!

3.06.3 All material used for the remote switch should be UL listed and installed per code.

3.06.4 The remote switch should be single

pole, single throw with at least a 1 Amp rating. The wire used should be at least 18 gauge.

3.06.5 The switch should be mounted at a convenient location with approved strain relief.

3.06.6 The remote switch should be connected to the violet wire extending from the unit, using the furnished connector. Connect the wire to the load side of the switch. Connect the line side of the remote switch to fused, positive battery. The actual load draw through the remote switch is less than .1 amp. The fuse should not be larger than the amp capacity of the switch or the hookup wire. A recommended fuse is a Bussman SFE-4 or Littlefuse 311-004.

3.07 120 VAC Output

3.07.1 The 120 VAC output of the inverter is provided by the GFCI receptacle output on the front of the inverter.

3.07.2 120 VAC power from the electric utility or generator can be connected to the inverter by plugging in the AC line cord if the inverter has the "T" option. This cord should be plugged into a grounded receptacle.

3.07.3 When the external 120 VAC is supplied, the internal transfer switch is automatically activated and the inverter is turned off. The inverter can not be turned on when the transfer switch is activated.

3.08 Automatic Battery Charger

3.08.1 When 120 VAC power is present to the inverter through the line cord the inverter is also automatically switched into the battery charger mode.

4. START UP/OPERATION

4.01 To operate the inverter turn the switch to "ON". Make sure that the output breaker and Ground Fault Circuit Interrupter are reset.

4.02 If installed and used, turn the remote switch to "On" position. The green LED on the inverter will light. The internal slide switch and the remote switch are not interconnected. You must turn the inverter "Off" from the same switch that turned the inverter "On".

4.03 The inverter should be turned "Off" when

not in use.

5. TROUBLESHOOTING

5.01 Dimensions Inc. offers free phone consultation concerning installation or troubleshooting. Call the Customer Service Department at: 1-800-553-6418 or 1-651-653-7000
fax: 1-651-653-7600
e-mail: inverterinfo@Airpax.net

5.02 If the inverter fails to operate, use the following troubleshooting procedure.

5.02.1 Connect a 100 watt light bulb to the inverter output.

5.02.2 Make sure that the inverter is turned on, the output circuit breaker is reset and that the line fuse is good.

5.02.3 Observe the fault indicating light on the front of the inverter. If the low battery light is lit, turn inverter "Off" for 5 seconds, then turn "On" again. If the low battery light turns on again, check battery wiring, battery state-of-charge and voltage.

5.02.4 If the inverter feels hot, it may have shut down due to high temperature. The inverter must be left to cool to 40 c (104 f). Check to see that the inverter is not in a closed compartment.

5.02.5 If the above steps are completed and the inverter still will not operate satisfactorily call Airpax Dimensions, Inc. for a return authorization number.

DIMENSIONS INVERTER

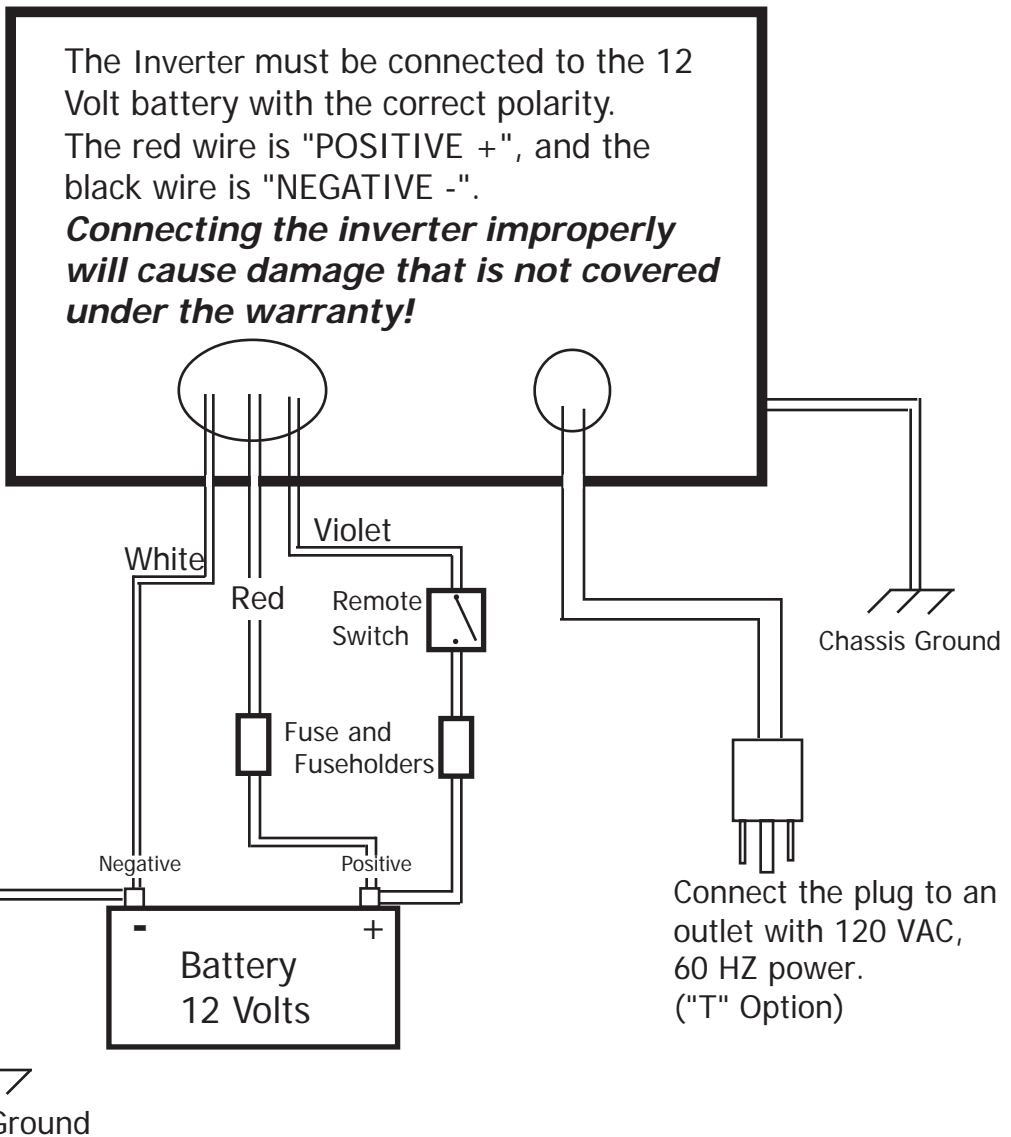

Figure #1 INSTALLATION DIAGRAM

Limited Warranty Terms & Conditions

SHIPPING TERMS

F.O.B. St. Paul Minnesota. Freight prepaid and billed, subject to prior credit approval.

MINIMUM ORDER

\$50.00 Net Price

LOSS OR DAMAGE

Loss or damage in transit are the responsibility of the carrier. Any claim should be filed with the delivering transport company. Invoice, Bill of Lading and Delivery receipt with damage noted therein must accompany any claims for freight damage. Claims for shortage and lost shipments must be made in writing to Airpax Dimensions, St. Paul, MN within 10 days of date of shipment. Claims not reported within this time frame will not be honored.

PRICES

Prices are subject to change without notice. All orders are subject to acceptance at the factory. We reserve the right to invoice prices in effect at time of shipment.

TERMS

Net 30 days with approved credit, credit card or C.O.D.

RETURN GOODS POLICY

o No returned materials will be accepted without an accompanying Returned Materials Authorization Number (RMA) from the factory.

o Credit will be issued for returned goods to the original purchaser within 60 days of purchase, provided the inverter is returned to Dimensions unused and not mounted. The amount of credit will be issued at Dimensions discretion based on the condition of the product.

o Customer must be in good standing with Dimensions.

o Inverters that are discontinued, high-voltage (over 24vdc), special-order or used are excluded and will not be eligible for credit. Non-inverter items such as cable assemblies, fuses and fuse holders, will not be eligible for credit

o Support components supplied by Dimensions vendors will be covered under that manufacturer's credit return policy.

o Customer pays return freight.

PLEASE SHIP AUTHORIZED RETURNS TO: Airpax Dimensions, Inc. / 4467 White Bear Parkway / St. Paul, MN 55110
Return Freight Prepaid

LIMITED WARRANTY

Airpax Dimensions, Inc. extends the following warranty to the original purchaser of those goods subject to the qualifications indicated.

Dimensions warrants to the original purchaser for use that the goods or any component thereof manufactured by Dimensions will be free from defects in workmanship for the period listed on the product label from the date of purchase, provided such goods are installed, maintained and used in accordance with Dimensions and the original manufacturer's written instructions.

Components not manufactured by Dimensions, but used within the assembly provided by Dimensions, are subject to the warranty period as specified by the individual manufacturer of said component, provided such goods are installed, maintained and used in accordance with Dimensions and the manufacturer's written instructions.

Dimensions sole liability and the Purchaser's sole remedy for a failure of goods under this limited warranty and for any and all claims arising out of the purchase and use of the goods, shall be limited to the repair or replacement of the goods that do not conform to this warranty.

To obtain repair or replacement service under the limited warranty, the purchaser must contact the factory for a Return Material Authorization (RMA). Once obtained, send the Return Material Authorization Number along with the defective part or goods to: Airpax Dimensions, Inc., 4467 White Bear Parkway, St. Paul, MN 55110, freight prepaid.

THERE ARE NO EXPRESS WARRANTIES COVERING THESE GOODS OTHER THAN AS SET FORTH ABOVE. THE IMPLIED WARRANTIES OF MERCHANTABILITY AND FITNESS FOR A PARTICULAR PURPOSE ARE LIMITED IN DURATION TO ONE YEAR FROM DATE OF PURCHASE.

DIMENSIONS ASSUMES NO LIABILITY IN CONNECTION WITH THE INSTALLATION OR USE OF THE PRODUCT, EXCEPT AS STATED IN THIS LIMITED WARRANTY. DIMENSIONS WILL IN NO EVENT BE LIABLE FOR INCIDENTAL OR CONSEQUENTIAL DAMAGES.

WARNING: LIMITATIONS ON USE

Dimensions products are not intended for use in connection with Life Support Systems and for Avionic use. Dimensions makes no warranty or representation in connection with their products for such uses.